

Compact Size

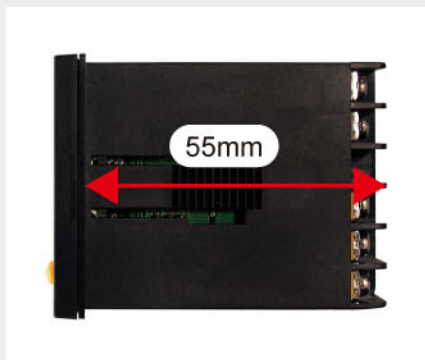

Saving space with the shortest length behind panel.



Large LED display



0.4" LED display showing SV/PV at a glance.



Front Waterproof



Front panel protection with NEMA-4/IP65. (The attached packing is required.)



High Sampling Rate



Higher sampling (100ms) result in better control performance.

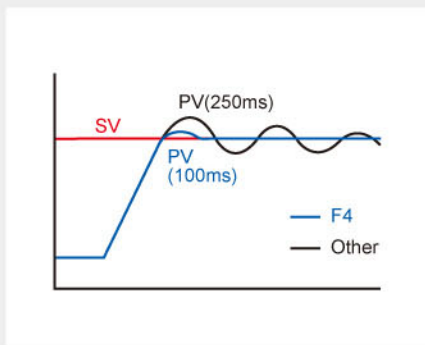

Ramp to Setpoint



Protect the control object from thermal shock (rapid temperature change) with the excellent ramp rate facility.

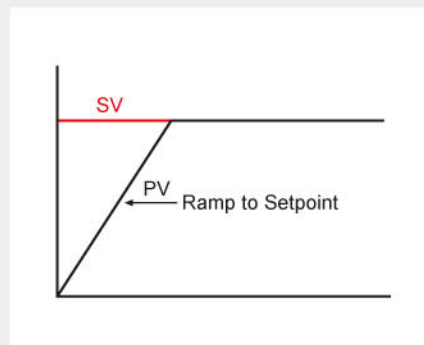

Soft Start



Protect the heating element from excess current during initial power-up.

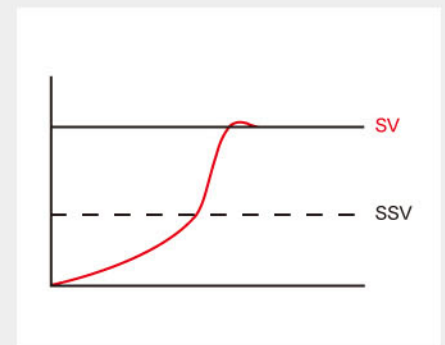

Specification

Input

Input signal: User programmable. refer to table 1

- Thermocouple (T/C): industry standard thermocouple types, J, K, T, E, B, R, S, N, C (ITS-90)
- Pt100: Excitation 180uA. 2 or 3 wire connection (ITS-90 $\alpha=0.00385$)
- Voltage: -60mVdc to 60mVdc or -10Vdc to 10Vdc
- Current: 0mA to 24mA

Sampling rate: 100mS

Measuring range: User programmable. Maximum range refer to table 1

Measuring accuracy: refer to Table 1. the accuracy is tested under the operating condition of 24°C±3°C

Table 1 Measuring Range & Accuracy

Input signal	Maximum Range	Accuracy
Thermocouple J	-50 to 1000°C (-58 to 1832°F)	±1°C
Thermocouple K*	-50 to 1370°C (-58 to 2498°F)	±1°C
Thermocouple T	-270 to 400°C (-454 to 752°F)	±1°C
Thermocouple E	-50 to 700°C (-58 to 1832°F)	±1°C
Thermocouple B	0 to 1750°C (32 to 1832°F)	±2°C (Note1)
Thermocouple R	-50 to 1750°C (-58 to 1832°F)	±2°C
Thermocouple S	-50 to 1750°C (-58 to 1832°F)	±2°C
Thermocouple N	-50 to 1300°C (-58 to 1832°F)	±2°C
Thermocouple C	-50 to 1800°C (-58 to 1832°F)	±2°C
Pt100	-200 to 600°C (-58 to 1832°F)	±0.2°C
Current	0.000 to 24.000mAdc	±3µA
mV	-60.00mVto 60.00mV	±0.01mV
Voltage	-10.000 to 10.000Vdc	±1mV

*Factory Setting

Note 1: Accuracy is not guaranteed between 0 and 400°C (0 and 752°F) for type B

Control

Control Output: User selectable

- Relay Contact Output: Form A/SPST Contacts 2A/240 VAC (Resistive load)
- Pulsed Voltage Output: DC 0/24V (Resistive load 250 Ω Min.)

Control Mode: PID with auto-tune, P with manual reset or On/Off with hysteresis available

- Proportional Band: 0.0~300.0% (0.0 % = On/Off mode)
- Integral Time: 0~3000 sec
- Derivative Time: 0~1000 sec
- Hysteresis: 0.0~999.9 or 0~9999
- Cycle Time: 1~60 sec

Alarm Output

Alarm Output: Form A/SPST Contacts 2A/240 VAC

Alarm Function: Energized / De-energized with 1s~99m 59s delay time

- No alarm
- Process high alarm
- Process low alarm
- Deviation high alarm
- Deviation low alarm
- Inside deviation band alarm
- Outside deviation band alarm

Alarm Mode:

- Normal mode
- Standby mode
- Latch mode
- Standby and Latch mode

Digital Communication

Communication:

- Interface: Based on EIA RS-485
- Protocol: ModBus RTU mode
- Data format:
 - Start bit: 1
 - Data bit: 8
 - Parity: None
 - Stop bit: 2
- Baud Rate: 2400, 4800, 9600, 19200 bps

General Specifications

Power supply: Universal 90~265 VAC 50/60Hz

Power consumption: 4VA Max.

Aux. 24Vdc power output: 25mA (max.)

Common mode rejection ratio: >80dB

Operating temperature: 0 to 50°C

Humidity: 0 to 85% RH (Non-Condense Condition)

Electromagnetic compatibility (EMC): En 50081-2, En 50082-2

Housing material: ABS plastic. UL 94V0

Weight: 100g (3.5 Oz)

Dimension

• Outline

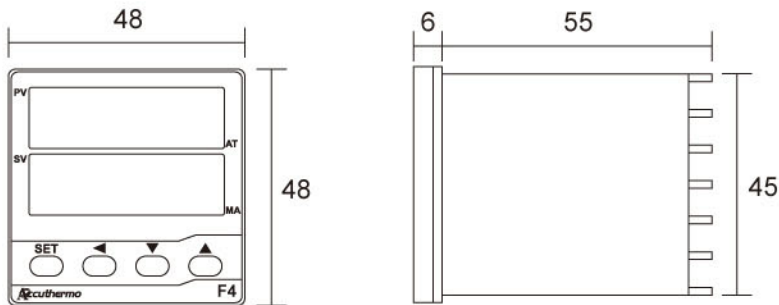

• Panel cut

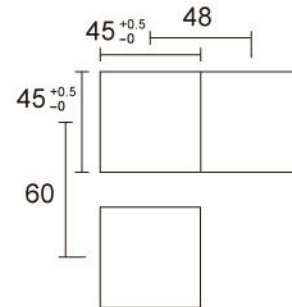

(Unit / mm)

Wiring Diagram

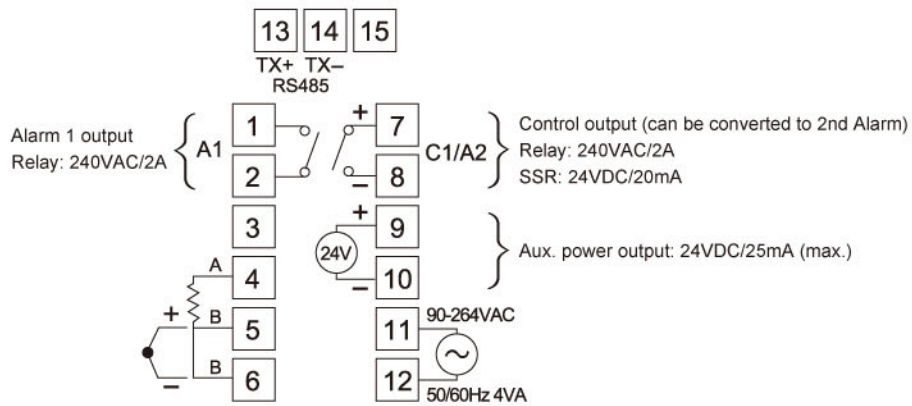

Ordering Information

F4



Input	Code
T/C	T
RTD	D
0mV to 60mV DC	L
0 to 10V DC	V
0 to 24mA DC	M

Output	Code
Relay	R
SSR	P
2nd Alarm	A

Communication	Code
None	N
RS-485	C



ACCUTHERMO TECHNOLOGY CORP.

45772 Bridgeport Dr., Fremont, CA 94539, USA

Phone : +1-408-685-0993

<http://www.accuthermo.com>